

BATU-EXAM

Made by batuexams.com

at MET Bhujbal Knowledge City

Engg Physics Department

The PDF notes on this website are the copyrighted property of batuexams.com.

All rights reserved.

2) Explain the significance of Miller indices and derive an expression for interplaner distance in terms of Miller indices for a cubic Structure.

Miller indices: are the reciprocals of intercepts made by the crystal planes on the crystallographic axes when reduced to smallest integers.

Important features of Miller indices:

- Miller indices represent a set of parallel equidistant planes.
- All the parallel equidistant planes have the same Miller indices.
- If a plane is parallel to any axis, then the plane intersects that axis at infinity and Miller indices along that direction is zero.
- If the miller indices of the two planes have the same ratio (844,422,211), then the planes are parallel to each other.
- If a plane cuts an axis on the -ve side of the origin, then the corresponding index is -ve, and is indicated by placing a minus sign above the index.

Ex: if a plane cuts -ve y-axis, then the miller index of the plane is $(h \bar{k} l)$

Derivation:

- Consider a crystal in which the three axes are orthogonal and the intercepts are same. Take 'o' as origin, and the reference plane passes through the origin i.e entirely lies on the axis.
- The next plane ABC is to be compared with the reference plane which makes the intercepts $\frac{a}{h}, \frac{b}{k}, \frac{c}{l}$ on x,y,z axes respectively.
- Let $(h k l)$ be the miller indices.
- Let ON=d be a normal drawn to the plane ABC from origin 'o' which gives the distance of separation between adjacent planes.
- Let the normal ON makes an angles α, β, γ with x,y,z axes respectively.
Angle $\alpha = \text{NOA}$, angle $\beta = \text{NOB}$, angle $\gamma = \text{NOC}$.

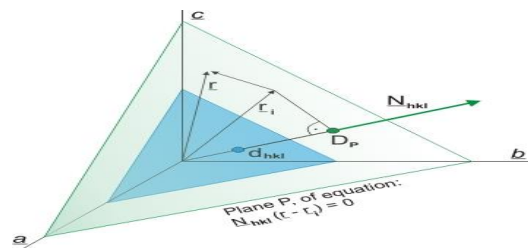

- Then form Δ le NOA
$$\cos \alpha = \frac{ON}{OA} = \frac{d}{a/h} = \frac{dh}{a}$$
- Similarly $\cos \beta = \frac{ON}{OB} = \frac{d}{b/k} = \frac{dk}{b}$
- $\cos \gamma = \frac{ON}{OC} = \frac{d}{c/l} = \frac{dl}{c}$
- According to cosine law of directions, $\cos^2 \alpha + \cos^2 \beta + \cos^2 \gamma = 1$
- Therefore $\left(\frac{dh}{a}\right)^2 + \left(\frac{dk}{b}\right)^2 + \left(\frac{dl}{c}\right)^2 = 1$
- $d^2 \left[\frac{h^2}{a^2} + \frac{k^2}{b^2} + \frac{l^2}{c^2}\right] = 1$
- In a cubic crystal $a = b = c$,
- Therefore
$$d^2 \left[\frac{h^2}{a^2} + \frac{k^2}{a^2} + \frac{l^2}{a^2}\right] = 1$$

- When electron beam accelerated by 54 V was directed to strike the given nickel crystal, a sharp max in the electron diffraction occurred at an angle of 50° with the incident beam.
- The incident beam and the diffracted beam make an angle of 65° with the family of Bragg's planes. The whole instrument is kept in an evacuated chamber.
- The spacing of planes in Nickel crystal as determined by x-ray diffraction is 0.091nm
- From Bragg's law $2d\sin\theta = n\lambda$ i.e $2 \times 0.091 \times 10^{-9} \times \sin 65^\circ = 1 \times \lambda$
 $\lambda = 0.615\text{nm}$
- Therefore for a 54 V electron beam, the de-Broglie wavelength associated with the electron is given by $\lambda = \frac{12.27}{\sqrt{54}} \text{ \AA} = 0.166\text{nm}$
- This wavelength agrees well with the experimental value. Thus division experiment provides a direct verification of de-Broglie hypothesis of wave nature of moving particles.

10) Explain the Physical significance of Ψ (wave function).

- The wave function Ψ enables all possible information about the particle. Ψ is a complex quantity and has no direct physical meaning. It is only a mathematical tool in order to represent the variable physical quantities in quantum mechanics.
- Born suggested that, the value of wave function associated with a moving particle at the position co-ordinates (x,y,z) in space, and at the time instant 't' is related in finding the particle at certain location and certain period of time 't'.
- If Ψ represents the probability of finding the particle, then it can have two cases.
Case 1: certainty of its Presence: +ve probability
Case 2: certainty of its absence: -ve probability, but -ve probability is meaningless,
Hence the wave function Ψ is complex number and is of the form $a+ib$
- Even though Ψ has no physical meaning, the square of its absolute magnitude $|\Psi^2|$ gives a definite meaning and is obtained by multiplying the complex number with its complex conjugate then $|\Psi^2|$ represents the probability density 'p' of locating the particle at a place at a given instant of time. And has real and positive solutions.

$$\Psi(x, y, z, t) = a + ib$$

$$\Psi^*(x, y, z, t) = a - ib$$

$$p = \Psi\Psi^* = |\Psi^2| = a^2 + b^2 \text{ as } i^2 = -1$$

Where 'P' is called the probability density of the wave function.

- If the particle is moving in a volume 'V', then the probability of finding the particle in a volume element dv , surrounding the point x,y,z and at instant 't' is Pdv

$$\int_{-\infty}^{\infty} |\Psi^2| dv = 1 \text{ if particel is present}$$

$$= 0 \text{ if particle does not exist}$$

This is called normalization condition.

11) Describe Heisenberg's uncertainty principle?

- According to Classical mechanics, a moving particle at any instant has fixed position in space and definite momentum which can be determined simultaneously with any desired accuracy. This assumption is true for objects of appreciable size, but fails in particles of atomic dimensions.

- Since a moving atomic particle has to be regarded as a de-Broglie wave group, there is a limit to measure particle properties.
- According to Born probability interpretation, the particle may be found anywhere within the wave group moving with group velocity.
- If the group is considered to be narrow, it is easier to locate its position, but the uncertainty in calculating its velocity and momentum increases.
- If the group is wide, its momentum is estimated easily, but there is great uncertainty about the exact location of the particle.
- Heisenberg a German scientist in 1927, gave uncertainty principle which states that "The determination of exact position and momentum of a moving particle simultaneously is impossible".

- In general, if Δx represents the error in measurement of position of particle along x-axis, and Δp represents error in measurement of momentum, then

$$\Delta x \cdot \Delta p = h$$

Or limitation to find the position and momentum of a particle is

$$(\Delta x) \cdot (\Delta p) \geq \frac{h}{4\pi}$$

i.e. Heisenberg uncertainty principle states that both the position and momentum Cannot be measured simultaneously with perfect accuracy.

12) Derive an expression for Schrodinger time independent wave equation.

- Schrodinger describes the wave nature of a particle in mathematical form and is known as Schrodinger's wave equation.
- Consider a plane wave moving along +ve x- direction with velocity 'v'. The equation of the wave is written in the form $y = a \sin \frac{2\pi}{\lambda} (x - vt) \dots (1)$
Where λ = wavelength of the wave, a= amplitude of wave
y=displacement of wave in y- direction
x=displacement along x- axis at any instant of time 't'.
- Taking first order derivative w.r.to 'x' on both sides of eqn (1)

$$\frac{dy}{dx} = a \cos \frac{2\pi}{\lambda} (x - vt) \frac{2\pi}{\lambda}$$

$$\frac{d^2y}{dx^2} = -a \left(\frac{2\pi}{\lambda}\right)^2 \sin \left(\frac{2\pi}{\lambda}\right) (x - vt) \dots (2)$$

Substitute (1) in (2)

$$\frac{d^2y}{dx^2} + \left(\frac{2\pi}{\lambda}\right)^2 y = 0 \dots (3)$$

- This is known as differential plane wave equation.
- In complex wave, the displacement 'y' is replaced by ' ψ ' and wavelength ' λ ' is replaced by de-Broglie's wavelength $\lambda' = \frac{h}{mv}$ in eqn (3)

$$\frac{d^2\psi}{dx^2} + \left(\frac{2\pi}{\lambda}\right)^2 \psi = 0$$

$$\frac{d^2\psi}{dx^2} + \frac{4\pi^2 m^2 v^2}{h^2} \psi = 0 \dots (4)$$

- For a moving particle, the total energy is $E = U + V$ i.e $E = U + V \dots(5)$

Where E= total energy, V= potential energy, U= kinetic energy = $\frac{1}{2}mv^2$

$2mu = m^2v^2 \dots (6)$, substitute (5) in (6)

$2m(E - V) = m^2v^2 \dots (7)$ Substitute (7) in (4)

$$\frac{d^2\psi}{dx^2} + \frac{4\pi^2 2m(E - V)}{h^2} \psi = 0$$

$$\frac{d^2\psi}{dx^2} + \frac{8\pi^2 m(E - V)}{h^2} \psi = 0 \dots (8)$$

- This equation is known as Schrodinger's time independent wave equation in one dimension.
- In three dimensions, it can be written as

$$\nabla^2 \psi + \frac{8\pi^2 m(E - V)}{h^2} \psi = 0 \dots (9)$$

$$\nabla^2 \psi + \frac{2m(E - V)}{h^2} \psi = 0$$

- For a free particle, the P.E is equal to zero i.e $V=0$ in equation (9)
- Therefore the Schrodinger's time independent wave equation for a free particle is

$$\nabla^2 \psi + \frac{8\pi^2 mE}{h^2} \psi = 0$$

13) Derive an expression for the energy states of a Particle trapped in 1-Dimensional potential box:

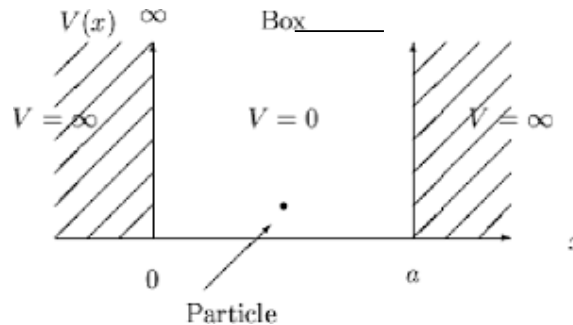

- The wave nature of a moving particle leads to some remarkable consequences when the particle is restricted to a certain region of space instead of being able to move freely .i.e when a particle bounces back and forth between the walls of a box.
- If one –dimensional motion of a particle is assumed to take place with zero potential energy over a fixed distance, and if the potential energy is assumed to become infinite at the extremities of the distance, it is described as a particle in a 1-D box, and this is the simplest example of all motions in a bound state.
- The Schrodinger wave equation will be applied to study the motion of a particle in 1-D box to show how quantum numbers, discrete values of energy and zero point energy arise.
- From a wave point of view, a particle trapped in a box is like a standing wave in a string stretched between the box's walls.
- Consider a particle of mass 'm' moving freely along x- axis and is confined between $x=0$ and $x= a$ by infinitely two hard walls, so that the particle has no chance of penetrating them and bouncing back and forth between the walls of a 1-D box.

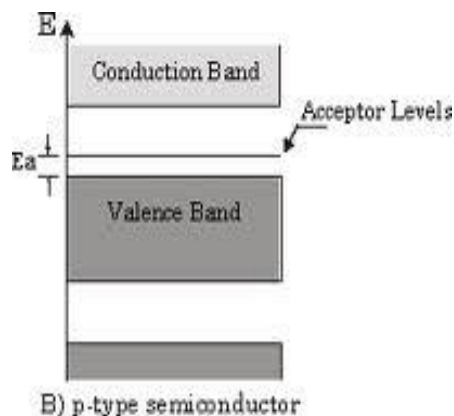

i.e. $2 \frac{E_v - E_f - E_f + E_a}{KT} = \frac{Na}{2 \left(\frac{2\pi m_p^* KT}{h^2} \right)^{3/2}}$

- Taking log, $\frac{E_v + E_a - 2E_f}{KT} = \log \frac{Na}{2 \left(\frac{2\pi m_p^* KT}{h^2} \right)^{3/2}} \rightarrow 2$
- At 0° K, $E_f = \frac{E_v + E_a}{2}$
i.e. At 0 K, Fermi level lies exactly at the middle of the acceptor level and in the top of the valance band.
- Sub. eqn. 2 in eqn. 1 & re-arranging, $P = (2Na)^{1/2} \left(\frac{2\pi m_p^* KT}{h^2} \right)^{3/4} \exp \left(\frac{E_v - E_a}{KT} \right)$
- Thus the density of the holes in the valance band is proportional to the square root of the acceptor concentration.

10. Explain Hall Effect in detail? What are its applications?

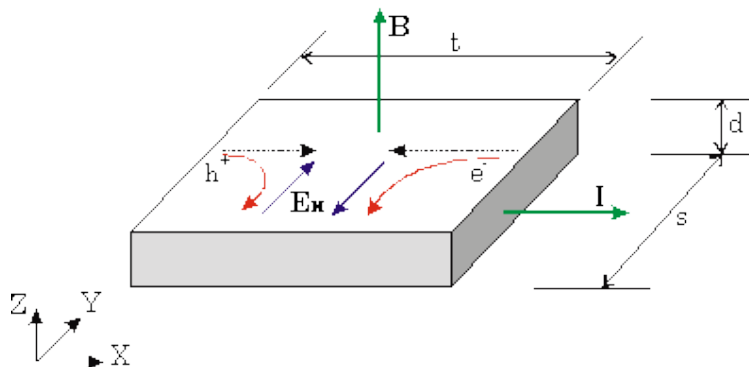

Hall-Effect:

- When a material carrying current is subjected to a magnetic field in a direction perpendicular to direction of current, an electric field is developed across the material in a direction perpendicular to both the direction of magnetic field and current direction. This phenomenon is called “Hall-effect”.

Explanation:

- Consider a semi-conductor, and current passes along the X-axis and a magnetic field Bz is applied along the Z-direction, a field Ey is called the Hall field which is developed in the Y-direction.

- In P-type semiconductor, holes move with the velocity “V” in the “+”ve X-direction. As they move across the semiconductor the holes experience a transverse force ‘Bev’ due to the magnetic field.
- This force drives the holes down to the lower face. As a result, the lower face becomes +vely charged and –ve charge on the upper surface creating the hall field in the Y-direction. The Hall field exerts an upward force on holes equal to E_e .
- In the steady state, two forces just balance and as a result, no further increase of + ve charge occurs on Face1.
- In N type semiconductor, the majority charge carriers are electrons experiences a force in the downward direction and lower face gets – vely charged. As a result, Hall field will be in the Y – direction.

Demonstration:

- Consider a rectangular slab of n-type semiconductor carrying current in the + ve X-direction.
- If magnetic field “B” is acting in the Z-direction as shown then under the influence of magnetic field, electrons experience a force given by $F_L = -Bev$.
- As a result of force F_H acting on the electrons in the Y – direction as a consequence the lower face of the specimen gets – vely charged and upper surface is + vely charged.
- Hence a potential V_H called the Hall Voltage present between the top and bottom faces of the specimen.
- The Hall field F_H , exerts an upward force on the electrons given by $F = -eE_H$
- The two opposing forces F_L and F_H establish an equilibrium under which
 $|F_L| = |F_H|$ i.e. $-Bev = -eE_H$

$$E_H = BV$$

- If ‘d’ is the thickness of the specimen, then $E_H = \frac{V_H}{d}$

$$V_H = E_H d$$

$$V_H = Bvd$$

- If ‘W’ is the width of the specimen, then $J = \frac{I}{wd}$

$$J = nev = \rho V$$

$$\Rightarrow V_H = \frac{Bid}{\rho wd} = \frac{Bi}{pw}$$

Hall Coefficient:

- Hall field E_H , for a given material depends on the current density J and the applied magnetic field B.

$$\text{i.e. } E_H \propto JB$$

$$E_H = R_H \propto JB$$

$$\text{Since, } V_H = \frac{Bi}{\rho w}, E_H = \frac{V_H}{d}$$

$$E_H = \frac{Bi}{\rho wd}$$

$$J = \frac{i}{wd}, \frac{Bi}{\rho wd} = R_H = \left(\frac{i}{wd}\right) B$$

$$\text{i.e. } R_H = \frac{1}{\rho}$$

Applications:**Determination of the type of Semi-conductors:**

The Hall coefficient R_H is -ve for an n-type semiconductor and +ve for p-type semiconductor. Thus the sign of Hall coefficient can be used to determine whether a given Semi-conductor is n or p-type.

Calculation of carrier concentration:

$$R_H = \frac{1}{\rho} = \frac{1}{ne} \quad (\text{for } e^- \text{ s})$$

$$R_H = \frac{1}{\rho e} \quad (\text{for holes})$$

$$\Rightarrow n = \frac{1}{eR_H}$$

$$\Rightarrow \rho = \frac{1}{eR_H}$$

Determination of Mobility:

If the conduction is due to one type carriers, ex: electrons

$$\sigma = ne\mu$$

$$\mu = \frac{\sigma}{ne} = \sigma R_H$$

$$\mu = \sigma R_H$$

Measurement of Magnetic Flux Density:

Hall Voltage is proportional to the magnetic flux density B for a given current I. so, Hall Effect can be used as the basis for the design of a magnetic flux density metal.

UNIT- 3: DIELECTRIC PROPERTIES & MAGNETIC MATERIALS

Part-A (SAQ-2Marks)

(1)Define the following terms (i)Electric dipole (ii)Dipole moment (iii) Dielectric constant (iv)Polarization (v)Polarization vector(vi) Electric displacement vector.

Electric dipole: Two equal and opposite charges small in magnitude and separated by a small distance constitute a electric dipole.

Dipole moment: The product of magnitude of both charge and the distance between the two charges. i.e. $\mu = q r$.

It is a vector quantity.

The direction of μ is from negative to positive.

Dielectric constant (ϵ_r): Dielectric constant is the ratio between the permittivity of the medium to the permittivity of the free space. $\epsilon_r = \frac{\epsilon}{\epsilon_0}$

Since it is the ratio of same quantity, ϵ_r has no unit.

Polarization: The process of producing electric dipoles which are oriented along the field direction is called polarization in dielectrics.

Polarization vector (P): The dipole moment per unit volume of the dielectric material is called polarization vector P.

$$P = \frac{\mu}{V}$$

If μ is the average dipole moment per molecule and N is the number of molecules per unit volume, then polarization vector, $P = N\mu = NaE$

Electric displacement vector is a quantity which is a very convenient function for analyzing the electrostatic field in the dielectrics and is given by $D = \epsilon_0 E + P$

- Let us consider small area ds on the surface of the sphere. This area is confined within an angle $d\theta$, making an angle θ with the direction of field E .
- 'q' is the charge on the area ds . Polarization P is parallel to E . P_N is the component of polarization perpendicular to the area ds .
- Polarization is defined as the surface charges per unit area.

$$\text{Here } q' = P \cos \theta ds$$

- Electric field intensity at A due to charge q' , $E = \frac{q'}{4\pi\epsilon_0 r^2} = \frac{P \cos \theta ds}{4\pi\epsilon_0 r^2}$
- Electric field intensity at c due to charge q' is given by coulombs law .Electric field intensity E is along the radius r . E is resolved into two components.
- Component of intensity parallel to the field direction $E_x = E \cos \theta$.
- Component perpendicular to the field direction $E_y = E \sin \theta$.
- The perpendicular components E_y and $(-E_y)$ are in opposite directions and hence cancel each other the parallel components alone are taken into consideration. By revolving ds about AB, we get a ring of area dA and radius

$$\text{➤ } E_x = E = \frac{P \cos \theta^2 dA}{4\pi\epsilon_0 r^2}$$

- Ring area $dA = \text{Circumference} \times \text{Thickness}$

$$= 2\pi y \times rd\theta \qquad \because \sin \theta = y/r$$

$$= 2\pi r \sin \theta \cdot rd\theta \qquad y = r \sin \theta$$

$$dA = 2\pi r^2 \sin \theta d\theta$$

- Electric field intensity = $\frac{P \cos \theta^2 \sin \theta d\theta}{2\epsilon_0}$

- Electric field intensity due to whole sphere is $E_3 = \int_0^\pi \frac{P \cos \theta^2 \sin \theta d\theta}{2\epsilon_0}$

$$= \frac{P}{3\epsilon_0}$$

$$\bullet E_{int} = E + \frac{P}{3\epsilon_0}$$

(5) Derive the Clasius-Mosotti relation based on local field? (Or) Derive an expression relating macroscopic dielectric constant and microscopic polarizability in case of symmetrical dielectric material?

- Let us consider the elemental dielectric having cubic structure as diamond, si, carbon etc. which have cubic structure. Since there is no ions or no permanent dipoles in these material the ionic polarizability α_i & orientational polarizability α_o are zero.

i.e. $\alpha_i = \alpha_o = 0$

- Polarization $p = N\alpha_e E_i = N\alpha_e (E + \frac{P}{3\epsilon_0})$

$$\text{➤ } p = \frac{N\alpha_e E}{(1 - \frac{N\alpha_e}{3\epsilon_0})} \text{----- (1)}$$

- We know $D = p + \epsilon_0 E$ and $P = \epsilon_0 E(\epsilon_r - 1)$ ----- (2)

$$\frac{N\alpha_e E}{(1 - \frac{N\alpha_e}{3\epsilon_0})} = \epsilon_0 E(\epsilon_r - 1)$$

$$\frac{\epsilon_r - 1}{\epsilon_r + 2} = \frac{N\alpha_e}{3\epsilon_0}$$

(6) Explain the classification of magnetic materials on the basis of magnetic moment and mention the important properties of various magnetic materials?

Classification of magnetic materials:

- By the application of magnetic field some materials will not show any effect that are called non magnetic materials and those which show some effects are called magnetic materials.
- All magnetic materials magnetized in the presence of external magnetic field.
- Depending on the direction and magnitude of magnetization and also the effect of temperature on magnetic properties, all magnetic materials are classified into Dia, Para and Ferro magnetic materials.
- Two more classes of materials have structure very close to Ferro magnetic materials, but shows quiet different magnetic properties. They are Anti-Ferro magnetic and Ferri magnetic materials.

Diamagnetism:

- The number of orientations of electronic orbits in an atom be such that vector sum of magnetic moment is zero
- The external field will cause a rotation action on the individual electronic orbits this produces an induced magnetic moment which is in the direction opposite to the field and hence tends to decrease the magnetic induction present in the substance.
- Thus the diamagnetism is the phenomena by which the induced magnetic moment is always in the opposite direction of the applied field.

Properties of diamagnetic materials:

- Diamagnetic material gets magnetized in a direction opposite to the magnetic field.
- Weak repulsion is the characteristic property of diamagnetism.
- Permanent dipoles are absent.
- Relative permeability is less than one but positive.
- The magnetic susceptibility is negative and small. It is not affected by temperature.
- Diamagnetism is universal i.e. all materials when exposed to external magnetic fields, tend to develop magnetic moments opposite in the direction to the applied field.
- When placed inside a magnetic field, magnetic lines of force are repelled.

Para magnetism:

- The number of orientations of orbital and spin magnetic moments be such that the vector sum of magnetic moment is not zero and there is a resultant magnetic moment in each atom even in the absence of applied field.
- The net magnetic moments of the atoms are arranged in random directions because of thermal fluctuations, in the absence of external magnetic field. Hence there is no magnetization.
- If we apply the external magnetic field there is an enormous magnetic moment along the field direction and the magnetic induction will be increase. Thus induced magnetism is the source of par magnetism.

Properties of paramagnetic materials:

- Paramagnetic materials get magnetized in the direction of the magnetic field.
- Weak attraction is characteristic property of Para magnetism.
- Paramagnetic material has magnetic dipoles.
- Relative permeability is greater than one but small i.e. this indicate that when paramagnetic substance is placed in a uniform magnetic field, the field inside the material will be more than the applied field.
- The magnetic susceptibility is small and positive. The magnetic susceptibility of paramagnetic is inversely proportional to absolute temperature i.e. $\chi=C/T$. This is called curie law, c is called Curie constant.
- Paramagnetic susceptibility is independent of the applied field strength.
- Spin alignment is random





- When placed inside a magnetic field it attracts the magnetic lines of force.
- Examples: Aluminum, Manganese, oxygen.

Ferromagnetism:

- Ferromagnetism arises when the magnetic moments of adjacent atoms are arranged in a regular order i.e all pointing in the same direction.
- The ferromagnetic substances possess a magnetic moment even in the absence of the applied magnetic field, this magnetization is known as the spontaneous magnetization.
- There is a special form of interaction called “exchange coupling” occurring between adjacent atoms, coupling their magnetic moment together in rigid parallelism.

Properties of ferromagnetic materials:

- In ferromagnetic materials, large magnetization occurs in the direction of the field.
- Strong attraction is the characteristic property of ferromagnetism.
- They exhibit spontaneous magnetization.
- The relative permeability is very high for Ferromagnetic.
- The magnetic susceptibility is positive and very high.
- Magnetic susceptibility is fairly high and constant up to a certain temperature according to the equation $\chi = \frac{C}{T - T_c}$ C = Curie constant T_c = Curie temperature.
- Ferromagnetism is due to the existence of magnetic domains which can be spontaneously magnetized.
- Exhibit hysteresis phenomenon.
- Spin alignment is parallel in the same direction 
- When placed inside a magnetic field they attract the magnetic lines of force very strongly.
- Examples: Iron, Nickel, Cobalt.

(7) Explain the hysteresis curve based on domain theory of ferromagnetism?

(OR)

Explain the hysteresis in a ferromagnetic material.

Domain theory of ferromagnetism:

- According to Weiss, the specimen of ferromagnetic material having number regions or domains which are spontaneously magnetized. In each domain spontaneous magnetization is due to parallel alignment of all magnetic dipoles.
- The direction of spontaneous magnetization varies from domain to domain.
- The resultant magnetization may hence be zero or nearly zero.
- When an external field is applied there are two possible ways for the alignment of domains.

(i) **By motion of domain walls:** The volume of domains that are favorably oriented with respect to the magnetizing field increases at the cost of those that are unfavorably oriented.

[Fig (b)]

(ii) **By rotation of domains:** when the applied magnetic field is strong, rotation of the direction of magnetization occurs in the direction of the field. [Fig(c)]

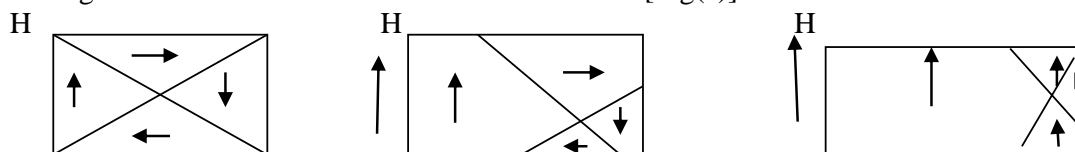
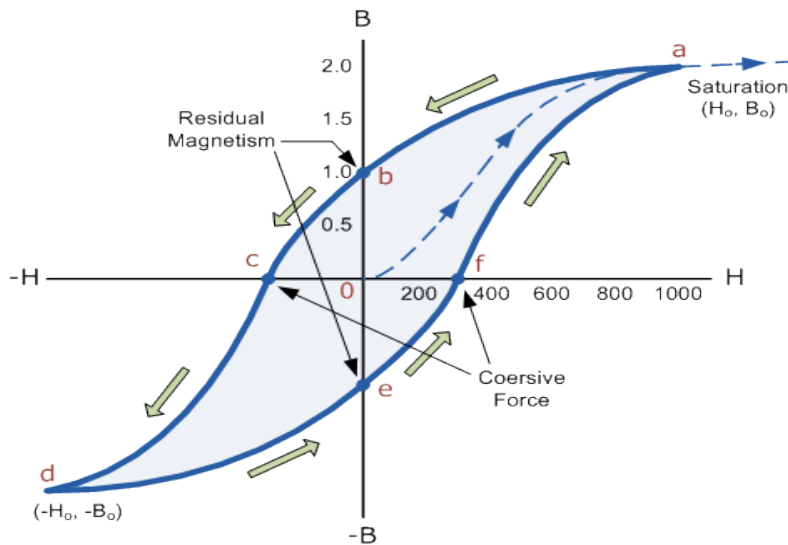

Fig (a)

fig (b)

fig(c)

Hysteresis curves

- **Hysteresis:** Lagging of magnetization behind the magnetizing field (H).
- When a Ferro magnetic material is subjected to external field, there is an increase in the value of the resultant magnetic moment due to two processes.
- The movement of domain walls
- Rotation of domain walls
- When a weak magnetic field is applied, the domains are aligned parallel to the field and magnetization grows at the expense of the less favorably oriented domains.
- This results in the Bloch wall (or) domain wall movement and the weak field is removed the domains reverse back to their original state. This reversible wall displacement is indicated by OA the magnetization curve.
- When the field becomes stronger than the domain wall movement, it is mostly reversible movement. This is indicated by path AB of the graph. The phenomenon of hysteresis is due to the irreversibility.
- At the point B all domains have got magnetized, application of higher field rotates the domains into the field direction indicated by BC. Once the domains rotation is complete the specimen is saturated denoted by C.
- Thus the specimen is said to be attain the maximum magnetization. At this position if the external field is removed ($H=0$), the magnetic induction B will not fall rapidly to zero ,but falls to D rather than O. This shows that even when the applied field is zero the material still have some magnetic induction (OD) which is called residual magnetism or retentivity.
- Actually after the removal of the external field the specimen will try to attain the original configuration by the movement of domain walls. But this movement is stopped due to the presence of impurities, lattice imperfections.
- Therefore to overcome this, large amount of reverse magnetic field (H_c) is applied to the specimen .The amount of energy spent to reduce the magnetization (B) to zero is called “coercivity” represented by OE in the fig.
- **HSTERESIS:** lagging of magnetization (B) behind the magnetizing field (H) is called hysteresis.

1) Explain i) Metastable state ii) optical pumping iii) population inversion

Metastable state: The excited state, which has a long life time, is known as metastable state.

Optical pumping: This process is required to achieve population inversion and used in Ruby laser.

Pumping process is defined as: “The process which excites the atoms from ground state to excited state to achieve population inversion”.

Population Inversion:

Generally, number of atoms in the ground state is greater than the number of atoms in higher energy states.

But in order to produce a laser beam, the minimum requirement is stimulated emission.

Stimulated emission takes place only if the number of atoms in the higher energy level is greater than the number of atoms in the lower energy level.

Simply population inversion is nothing but number of atoms in higher energy level is greater than the number of atom in lower energy level.

2) Define spontaneous and stimulated emission of radiation?

Spontaneous Emission: When an atom in the excited state emits a photon of energy ‘ $h\nu$ ’ coming down to ground state by itself without any external agency, such an emission is called spontaneous emission. $\text{Atom}^* \rightarrow \text{atom} + h\nu$.

Photons released in spontaneous emission are not coherent. Hence spontaneous emission is not useful for producing lasers.

Stimulated Emission: When an atom in the excited state, emits two photons of same energy ‘ $h\nu$ ’ while coming to down to ground state with the influence of an external agency, such an emission is called stimulated emission. $\text{Atom}^* \rightarrow \text{atom} + 2h\nu$.

- In the two photons one photon induces the stimulated emission and the second one is released by the transition of atom from higher energy level to lower energy level.
- Both the photons are strictly coherent. Hence stimulated emission is responsible for laser production.

3) Explain the basic principle of optical fiber?

- Optical fibers are the waveguides through which electromagnetic waves of optical frequency range can be guided through them to travel long distances.
- An optical fiber works on the principle of total internal reflection (TIR).
- **Total Internal Reflection:** when a ray of light travels from a denser medium into a rarer medium and if the angle of incidence is greater than the critical angle then the light gets totally reflected into the denser medium

4) Explain i) Numerical Aperture ii) Acceptance angle**i) Numerical Aperture:**

Numerical aperture of a fiber is a measure of its light gathering power.

“The Numerical Aperture (NA) is defined as the sine of the maximum acceptance angle”

The light gathering ability of optical fiber depends on two factors i.e.,

- Core diameter
- NA

NA is defined as sine of the acceptance angle

i.e., $NA = \sin \theta_A$ i.e. $NA = \sqrt{n_1^2 - n_2^2}$

The efficiency of optical fiber is expressed in terms of NA; it is called as figure of merit of optical fiber.

ii) Acceptance Angle:

All right rays falling on optical fiber are not transmitted through the fiber.

Only those light rays making $\theta_i > \theta_c$ at the core-cladding interface are transmitted through the fiber by undergoing TIR. For which angle of incidence, the refraction angle is greater than 90° will be propagated through TIR.

There by Acceptance Angle is defined as: The maximum angle of incidence to the axis of optical fiber at which the light ray may enter the fiber so that it can be propagated through TIR.

5. What are the main sections of optical fiber? Describe the step index optical fiber?

- An optical fiber consists of three (3) co-axial regions.
- The inner most region is the light-guiding region known as “Core”. It is surrounded by a middle co-axial regional known as “cladding”. The outer most regions which completely covers the core & cladding regions is called “sheath or buffer jacket”.
- Sheath protects the core & cladding regions from external contaminations, in addition to providing mechanical strength to the fiber.
- The refractive index of core (n_1) is always greater than the refractive index of cladding (n_2) i.e., $n_1 > n_2$ to observe the light propagation structure of optical fiber.

Step Index optical fiber:

- Based on variation in the core refractive index (n_1), optical fibers are divided in to two types
 1. Step index fiber
 2. Graded index fiber
- Step index fibers have both single & multimode propagations.

6) Write a short note on attenuation in optical fibers.

Usually, the power of light at the output end of optical fiber is less than the power launched at the input end, then the signal is said to be attenuated.

Attenuation: It is the ratio of input optical power (P_i) in to the fiber to the power of light coming out at the output end (P_o).

Attenuation coefficient is given as, $\alpha = 10/L \log_{10} P_i / P_o$ db/km.

Attenuation is mainly due to

1. Absorption.
2. Scattering.
3. Bending.

7) Write down advantages of fiber optics in communication system Or What are the Advantages of optical fibers over metallic cables?

- Optical fibers allow light signals of frequencies over a wide range and hence greater volume of information can be transmitted either in digital form or in analog form within a short time.

radiant Energy in devices like LED's, population Inversion is achieved in forward bias.

5) What are Einstein's coefficients and explain the relation among them?

or

Derive the relation between the probabilities of spontaneous emission and stimulated emission in terms of Einstein's coefficient?

Einstein's Theory of Radiation:

- In 1917, Einstein predicted the existence of two different kinds of processes by which an atom emits radiation.
- Transition b/w the atomic energy states is statistical process. It is not possible to predict which particular atom will make a transition from one state to another state at a particular instant. For an assembly of very large number of atoms it is possible to calculate the rate of transitions b/w two states.
- Einstein was the first to calculate the probability of such transition, assuming the atomic system to be in equilibrium with electromagnetic radiation.
- The number of atoms excited during absorption in the time ' Δt ' is given by: $N_{ab} = Q N_1 B_{12} \Delta t$, Where N_1 = number of atoms in state ' E_1 ', Q = Energy density of induced beam and B_{12} = Probability of an absorption transition coefficient.
- The number of spontaneous transitions N_{sp} taking place in time ' Δt ' depends on only no. of atoms N_2 lying in excited state. $N_{sp} = A_{21} N_2 \Delta t$, Where A_{21} = probability of spontaneous transition.
- The number of stimulated transitions N_{st} occurring during the time Δt may be written as: $N_{st} = B_{21} N_2 \Delta t$, Where B_{21} = probability of stimulated emission.
- Under the thermal equilibrium number of upward transitions = number of downward transitions per unit volume per second.
- So, we can write: $A_{21} N_2 + B_{21} N_2 Q = B_{12} N_1 Q \rightarrow 1$
- $Q = A_{21} N_2 / B_{12} N_1 - B_{21} N_2 \rightarrow 2$
- Dividing by $B_{21} N_2$ in all terms, $Q = (A_{21} / B_{21}) \times 1 / (B_{12} N_1 / B_{21} N_2) - 1 \rightarrow 3$
- By substituting $N_1 / N_2 = \exp(h\nu/kT)$ from Boltzmann Distribution law,
- $Q = (A_{21} / B_{21}) 1 / (B_{12} / B_{21}) \exp(h\nu/kT) - 1 \rightarrow 4$
- Above equation must agree with planks energy distribution – radiation formula.
 $Q = \frac{h\nu^3}{\pi^2 C^3} \frac{1}{\exp(h\nu/kT) - 1} \rightarrow 5$
- From equations 4 & 5, $B_{12} = B_{21}$, we get $A_{21} / B_{21} = \frac{h\nu^3}{\pi^2 C^3}$
- The co-efficients A_{21} , B_{12} , B_{21} are known as Einstein coefficients.
- Note: Since we are applying same amount of energy (Q) and observing in the same time (Δt), number of atoms excited into higher energy levels (absorption) = number of atoms that made transition into lower energy levels (stimulated emission)
 $B_{12} = B_{21}$ i.e. absorption = stimulated emission

6) Describe the principle, construction and working of ruby laser with relevant energy level diagram?

- **Ruby Laser:** It is a 3 level solid state laser, discovered by Dr.T.Maiman in 1960.
- **Principle:**
- The chromium Ions raised to excited states by optical pumping using xenon flash lamp
- Then the atoms are accumulated at metastable state by non-radiative transition.

- Due to stimulated emission the transition of atoms take place from metastable state to ground state, there by emitting laser beam.

- **Construction:**

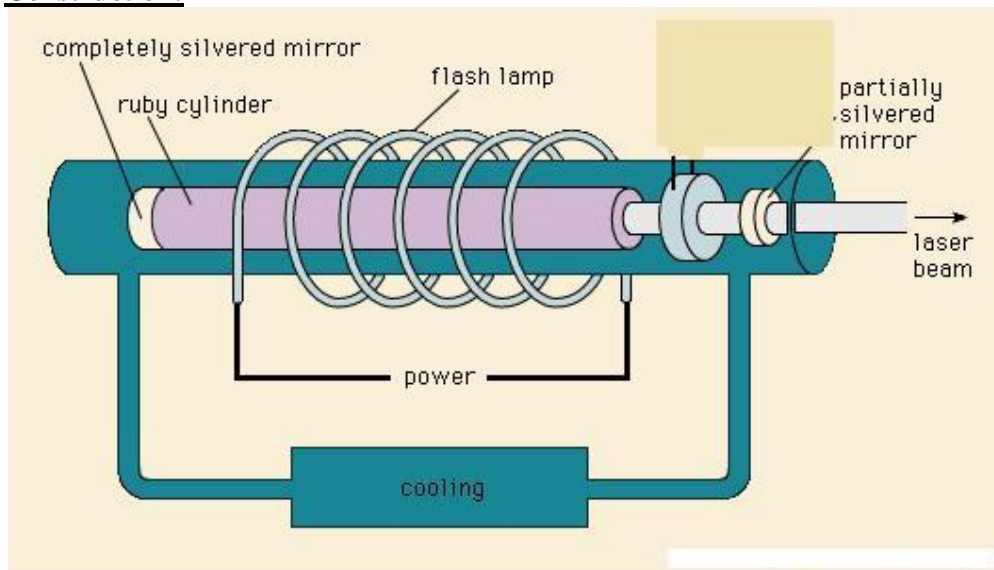

- Ruby is a crystal of aluminum oxide (Al_2O_3) in which some of the aluminum ions (Al^{3+}) is replaced by chromium ions (Cr^{3+}). This is done by doping small amount (0.05%) of chromium oxide (Cr_2O_3) in the melt of purified Al_2O_3 .
- These chromium ions give the pink color to the crystal. Laser rods are prepared from a single crystal of pink ruby. Al_2O_3 does not participate in the laser action. It only acts as the host.
- The ruby crystal is in the form of cylinder. Length of ruby crystal is usually 2 cm to 30 cm and diameter 0.5 cm to 2 cm.
- The ends of ruby crystal are polished, grounded and made flat.
- The one of the ends is completely silvered while the other one is partially silvered to get the efficient output. Thus the two polished ends act as optical resonator system.
- A helical flash lamp filled with xenon is used as a pumping source. The ruby crystal is placed inside a xenon flash lamp. Thus, optical pumping is used to achieve population inversion in ruby laser.
- As very high temperature is produced during the operation of the laser, the rod is surrounded by liquid nitrogen to cool the apparatus.
- **Working with Energy Level Diagram (ELD):**

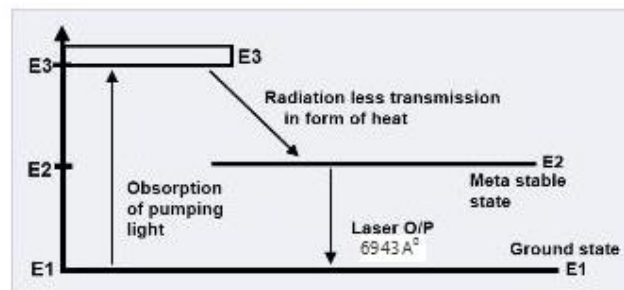

▪ Fig: Energy Level Diagram of Ruby Laser

- The flash lamp is switched on, a few thousand joules of energy is discharged in a few milliseconds.
- A part of this energy excites the Cr^{3+} Ions to excited state from their ground state and the rest heats up the apparatus can be cooled by the cooling arrangement by passing liquid nitrogen.
- The chromium ions respond to this flash light having wavelength 5600 \AA ⁰(Green), [4200 \AA ⁰(Red)Also]
- When the Cr^{3+} Ions are excited to energy level E_3 from E_1 the population in E_3 increases.
- Cr^{3+} Ions stay here(E_3) for a very short time of the order of 10^{-8} sec, then they drop to the level E_2 which is metastable state of lifetime 10^{-3} sec .Here the transitions from E_3 to E_2 is non radiative in nature.
- As the lifetime of the state E_2 is much longer, the number of ions in this state goes on increasing while in the ground state (E_1) goes on decreasing. By this process population inversion is achieved between E_2 & E_1 .
- When an excited ion passes spontaneously from the metastable state E_2 to the ground state E_1 it emits a photon of wavelength 6943 \AA ⁰.
- This photon travels through the ruby rod and if it is moving parallel to the axis of the crystal, is reflected back & forth by silvered ends until it stimulates an excited ion in E_2 and causes it to emit fresh photon in phase with the earlier photon. This stimulated transition triggers the laser Transition.
- The process is repeated again and again, because the photons repeatedly move along the crystal being reflected from ends. The photons thus get multiplied.
- When the photon beam becomes sufficiently intense, such that a part of it emerges through the partially silvered end of the crystal.

7) Describe the principle, construction and working of He-Ne laser with relevant energy level diagram?

- **He-Ne Laser:**
- **Principle:** This laser is based on the principle of stimulated emission, produced in the active medium of gas. Here, the population inversion achieved due to the interaction between the two gases which have closer higher energy levels.
- **Construction:**

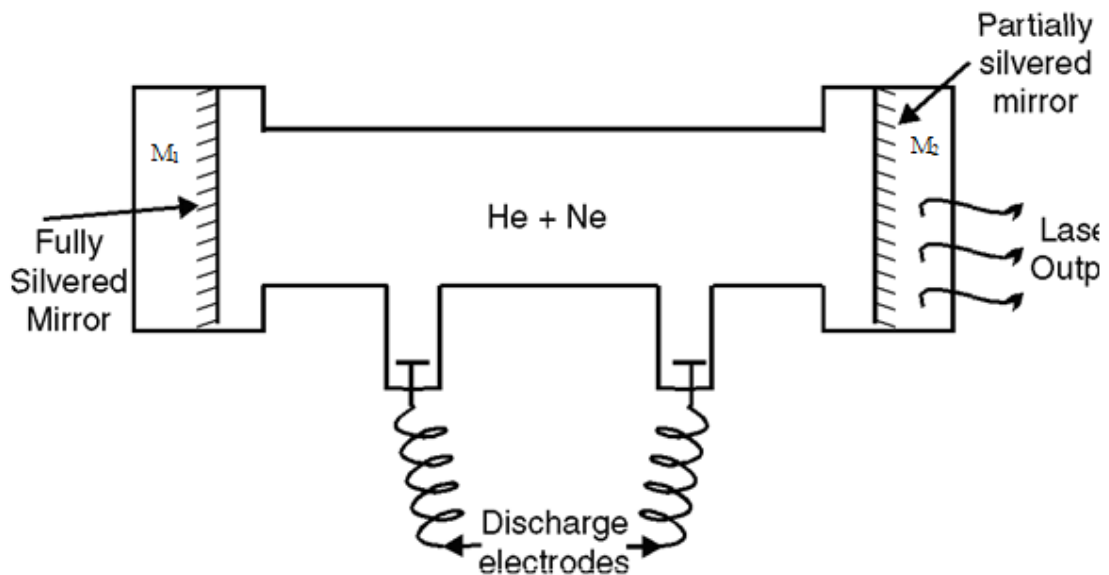

▪ Fig: He-Ne laser

- The first gas laser to be operated successfully was the He-Ne laser in 1961 by the scientist A. Javan.
- In this method, two gases helium & Neon were mixed in the ratio 10:1 in a discharge tube made of quartz crystal.
- The dimensions of the discharge tube are nearly 80 cm length and 1.5 cm diameter, with its windows slanted at Brewster's angle i.e., $\theta = \tan^{-1}(n)$, Where n = refractive index of the window substance.
- The purpose of placing Brewster windows on either side of the discharge tube is to get plane polarized laser output.
- Two concave mirrors M_1 & M_2 are made of dielectric material arranged on both sides of the discharge tube so that their foci lines within the interior of discharge tube.
- One of the two concave mirrors M_1 is thick so that all the incident photons are reflected back into lasing medium.
- The thin mirror M_2 allows part of the incident radiation to be transmitted to get laser output.
- Working:

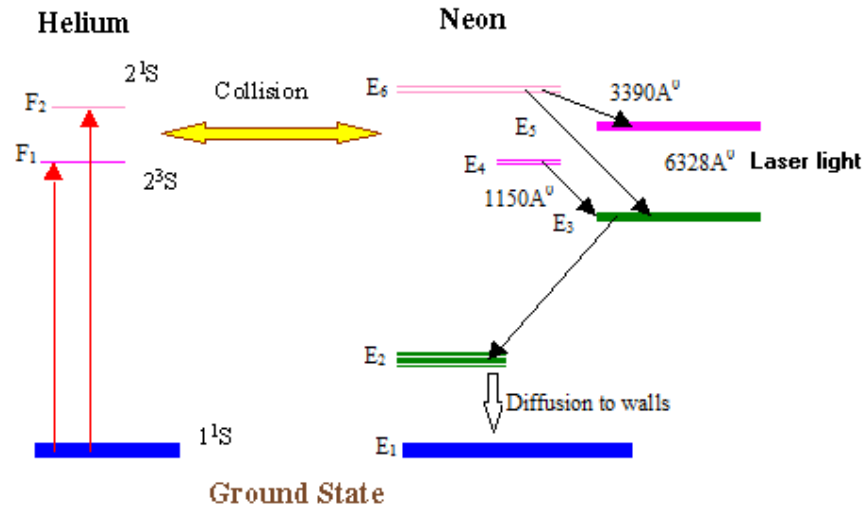
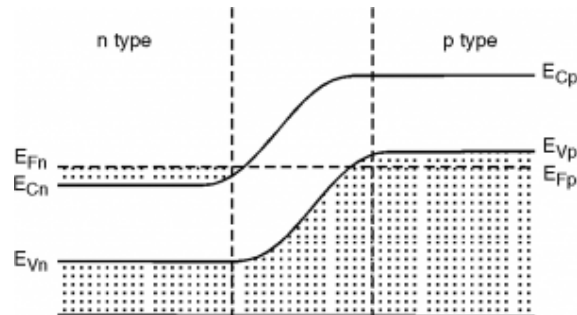
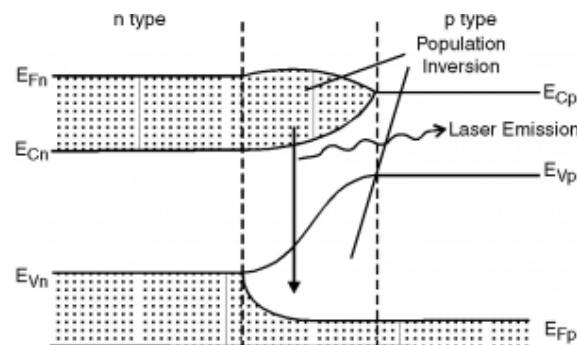

Fig:(E.L.D) Energy Level Diagram corresponding to He-Ne laser

- The discharge tube is filled with Helium at a pressure of 1 mm of Hg & Neon at 0.1mm of Hg.
- When electric discharge is set-up in the tube, the electrons present in the electric field make collisions with the ground state He atoms.
- Hence ground state He atoms get excited to the higher energy levels F_1 ($2S_1$), F_2 ($2S_3$).
- Here Ne atoms are active centers.
- The excited He atoms make collision with the ground state Ne atoms and bring the Ne atoms into the excited states E_4 & E_6 .
- The energy levels E_4 & E_6 of Ne are the metastable states and the Ne atoms are directly pumped into these energy levels.
- Since the Ne atoms are excited directly into the levels E_4 & E_6 , these energy levels are more populated than the lower energy levels E_3 & E_5 .
- Therefore, the population inversion is achieved between E_6 & E_5 , E_6 & E_3 , E_4 & E_3
- The transition between these levels produces wavelengths of 3390 \AA , 6328 \AA , 1150 \AA respectively.
- Now The Ne atoms undergo transition from E_3 to E_2 and E_5 to E_2 in the form of fast decay giving photons by spontaneous emission. These photons are absorbed by optical elements placed inside the laser system.
- The Ne atoms are returned to the ground state (E_1) from E_2 by non radiative diffusion and collision process, therefore there is no emission of radiation.
- Some optical elements placed inside the laser system are used to absorb the IR laser wavelengths 3390 \AA , 1150 \AA .
- Hence the output of He-Ne laser contains only a single wavelength of 6328 \AA .
- The released photons are transmitted through the concave mirror M_2 there by producing laser.
- A continuous laser beam of red color at a wavelength of 6328 \AA .
- By the application of large potential difference, Ne atoms are pumped into higher energy levels continuously.
- A Laser beam of power 0.5 to 50 MW comes out from He-Ne laser.

- Hetrojunction means the material on one side of the junction differs from that on the other side.i.e;Ga-As on one side and GaAlAs on other side.
- Generation and recombination takes place very fastly.

Working:**Fig a) when no biasing****Fig b) with biasing**

- When a forward bias with the source is applied to a semiconductor, e from N-region & holes from P-region move to cross the junction in opposite directions.
- In natural region the e's & holes combine recombination is possible due to transition of e from CB to VB.
- For low currents the population inversion does not take place hence only spontaneous emission takes place and photon released are not coherent.
- When forward current is further increased beyond the certain threshold value population inversion takes place and coherent photons are released.
- The energy gap of Gallium Arsenide (Ga-As) is 1.487eV and corresponding wavelength of radiation is 6435 \AA which is responsible for laser emission.

9) Mention some important applications of Lasers in various fields?

Applications of Lasers: Lasers have wide applications in different branches of science and engineering because of the following.

- Very narrow band width
- High directionality
- Extreme brightness

1. Communication:

- Lasers are used in optical communications, due to narrow band width.
- The laser beam can be used for the communication b/w earth & moon (or) other satellites due to the narrow angular speed.
- Used to establish communication between submarines i.e; under water communication.

2. Medical:

- Identification of tumors and curification.
- Used to detect and remove stones in kidneys.
- Used to detect tumors in brain.

3. Industry:

- Used to make holes in diamond and hard steel.
- Used to detect flaws on the surface of aero planes and submarines.

4. Chemical & Biological:

- Lasers have wide chemical applications. They can initiate or fasten chemical reactions.
- Used in the separation of isotopes.
- Lasers can be used to find the size & shape biological cells such as erythrocytes.

10. with the help of a suitable diagram explain the principle, structure and working of an optical fiber as a wave guide?

Principle: Optical fibers are the waveguides through which electromagnetic waves of optical frequency range can be guided through them to travel long distances.

- An optical fiber works on the principle of total internal reflection (TIR).

Total Internal Reflection: when a ray of light travels from a denser medium into a rarer medium and if the angle of incidence is greater than the critical angle then the light gets totally reflected into the denser medium

Structure & Working:

- An optical fiber consists of three (3) co-axial regions.
- The inner most region is the light-guiding region known as “Core”. It is surrounded by a middle co-axial regional known as “cladding”. The outer most regions which completely covers the core & cladding regions is called “sheath or buffer jacket”.
- Sheath protects the core & cladding regions from external contaminations, in addition to providing mechanical strength to the fiber.
- The refractive index of core (n_1) is always greater than the refractive index of cladding (n_2) i.e., $n_1 > n_2$ to observe the light propagation structure of optical fiber.
- When light enters through one end of optical fiber it undergoes successive total internal reflections and travel along the fiber in a “zig-zag” path.

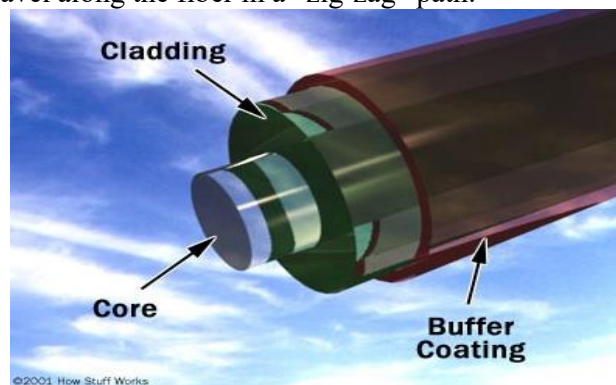

11) Define and derive the expressions for acceptance angle and numerical Aperture?

Expressions for acceptance angle & Numerical Aperture (NA):

Acceptance Angle:

- All right rays falling on optical fiber are not transmitted through the fiber. Only those light rays making $\theta_i > \theta_c$ at the core-cladding interface are transmitted through the

fiber by undergoing TIR. For which angle of incidence, the refraction angle is greater than 90° will be propagated through TIR.

- There by Acceptance Angle is defined as: The maximum angle of incidence to the axis of optical fiber at which the light ray may enter the fiber so that it can be propagated through TIR.

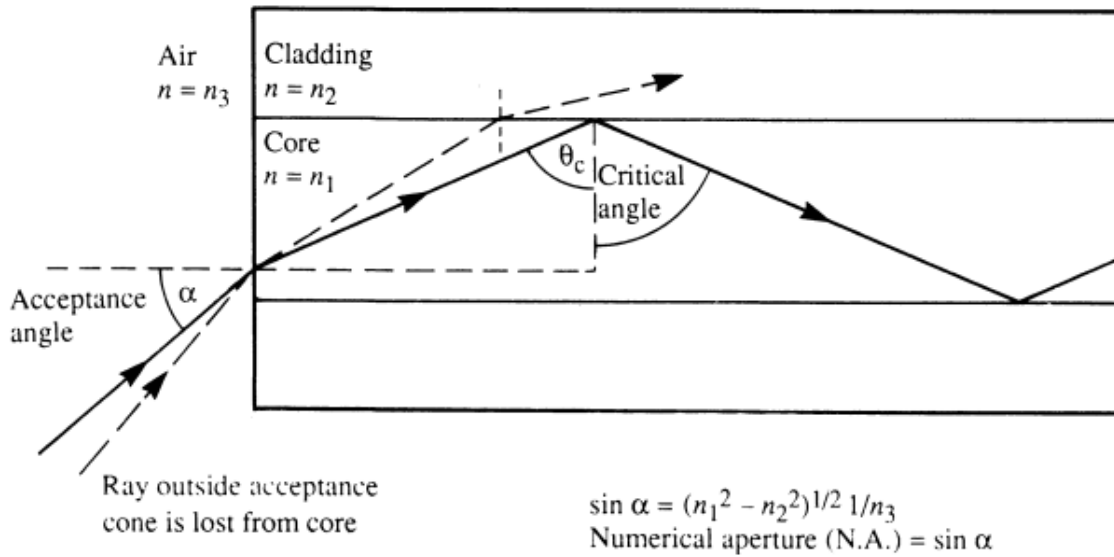

- Consider the optical fiber with core refractive index n_1 and cladding refractive index n_2 . Light is incident on the axis of optical fiber at an angle θ_1 . It can produce an angle of refraction θ_2 .
- The relationship at the interface is given by snell's law as:
 At air-core interface (A), $n_0 \sin \theta_1 = n_1 \sin \theta_2$ ----- 1
 At core-clad interface (B), for TIR, $n_1 \sin (90 - \theta_2) = n_2 \sin 90^\circ$
 $n_1 \cos \theta_2 = n_2$, $\cos \theta_2 = n_2 / n_1$ ----- 2
- Eq'n 1 can be written as $n_0 \sin \theta_1 = n_1 \sqrt{1 - \cos^2 \theta_2}$ ----- 3
- Substituting 2 in 3, $n_0 \sin \theta_1 = n_1 \sqrt{1 - n_2^2 / n_1^2}$
 $n_0 \sin \theta_1 = \sqrt{n_1^2 - n_2^2}$
- For air $n_0 = 1$, then $\sin \theta_1 = \sqrt{n_1^2 - n_2^2}$
- $\theta_1 = \theta_A = \sin^{-1} \sqrt{n_1^2 - n_2^2}$, Here θ_A is called Acceptance angle
- This gives max value of external incident angle for which light will propagate in the fiber.

Numerical Aperture (NA):

Numerical Aperture

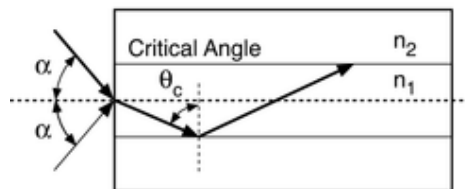

$NA = \sin \alpha = \sqrt{n_1^2 - n_2^2}$
 Full Acceptance Angle = 2α

BATU-EXAM

Made by batuexams.com

at MET Bhujbal Knowledge City

The PDF notes on this website are the copyrighted property of batuexams.com.

All rights reserved.